

# Programming and operating instructions

## Introduction

RX1 & RX2 Receivers are designed to operate with ASK radio transmitters working in the 304Mhz frequency band. The RX1 is a single channel Receiver and the RX2 is a dual channel Receiver. The RX1/2 can store up to 20 Radio Key codes. On the RX1 all 20 radio codes will operate relay output #1 (RL1). On the RX2 the first 10 radio key codes (1-10) will operate RL1 and the last 10 radio key codes (11-20) will operate RL2. The RX1/2 receivers also provide links for Momentary or Latched (Toggle) operation on each channel via the "A" link. **The board can be powered from a 12V- 24V AC or DC supply (using the 0V & 24V terminals). There is also a 12V DC output from the board which can provide 12V DC @ 50mA maximum.**

## Programming & Operation

There are four modes that can be accessed via the learn button. They are;

### **1-Learn Mode**

### **2-Individual Erase Mode**

### **3-Erase All Programmed Data Mode**

### **4-Find Programmed Slot Number Mode**

A description of each mode follows;

#### **1-Learn Mode**

To program a Radio Transmitter into one of the 20 memory slots you must first get into "Learn Mode". To do this you have to press the "Learn" button momentarily (press and release the button in less than 1 second). This will bring you to Slot # 1. To move to another slot, continue pressing the "Learn" button momentarily, counting each press to keep track of the slot number you are up to. Each press of the "Learn" button should be repeated within 1 second as you move through the slots. After 2 seconds of no further presses of the "learn" button, LED's 1,2 & 3 will indicate the current Slot number (please refer to Chart 1 for further details), e.g. Slot 3 = 3 flashes of LED 1, Slot 12 = LED 3 On and 2 flashes on LED 1.

Two seconds later the receiver will repeat the slot number display then enter "Learn Mode" for the slot indicated. "Learn Mode" is indicated by LED's 2 & 3 flashing together. Learn Mode is active for 30 seconds during which time you should operate the transmitter button that you wish to learn into the receiver. Pressing the "learn" button for longer than 1 second during "Learn Mode" will return the receiver back to normal mode.

When a valid transmission is received in learn mode, LED's 2 & 3 will stop flashing and LED's 1,2 & 3 will then flash back the slot number where the transmitter was stored. The slot number indication will be repeated every two seconds until one of two things happen.

- A-The "learn" button is pressed again for less than 1 second to move on to the next slot number or,
- B-The "learn" button is pressed for longer than 2 seconds which will stop the display and exit "Learn Mode" (all LED's off).

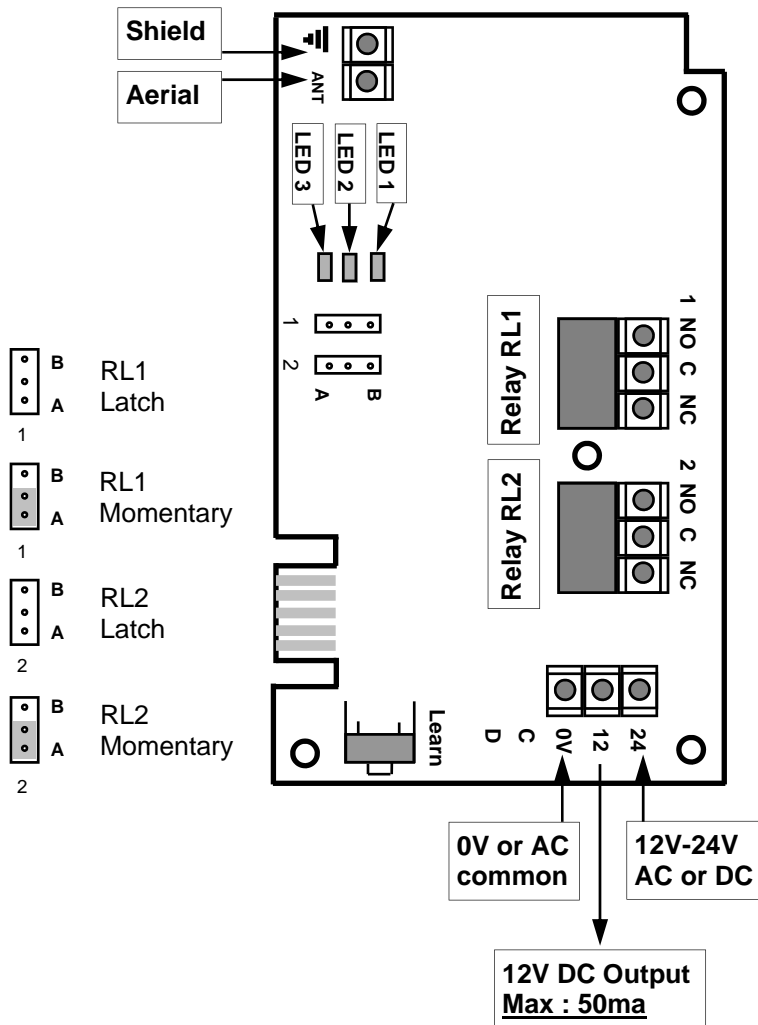

There are 20 slots where radio codes may be saved and Chart 1 shows the various combinations of the LED's to indicate each slot. Also, when multiple transmitters are used be sure to record who the transmitter is issued to in the chart so that if a transmitter is lost you can delete the correct one.

**2-Individual Erase Mode**

To Erase an individual transmitter you must follow the same procedure as Learning by pressing the "Learn" button repeatedly for less than 1 second at a time until you get to the desired slot number (e.g. 3 presses = slot # 3 which is indicated by 3 flashes on LED 1). Once you reach the desired slot you wish to erase, the slot number will be displayed twice. After the first indication of the slot number but before the second display has finished, press and hold the "learn" button for more than 2 seconds to Erase the selected slot. LED 1 will turn on to show that the erase mode is selected. When the slot has been erased, LED's 1&3 will flash simultaneously until the "learn" button is released, then the receiver will return to normal mode automatically.

**3-Erase All Programmed Data Mode**

To erase ALL stored transmitter codes, you must press and hold the "learn" button for longer than 4 seconds.

To do the bulk erase function the receiver must be in normal mode (not learn or find modes). Two seconds after holding the "Learn" button on, LED's 2&3 will flash alternately. Continue holding the learn button on past this time for another two seconds at which time LED 3 will turn on solid. This indicates that ALL stored codes have now been erased.

**4-Find Programmed Slot Number Mode**

If the receiver is in normal mode and the "learn" button is pressed for more than 2 seconds, but less than 4 seconds, LED's 2 & 3 will flash alternately to indicate that the "Find Slot Number" mode has been accessed (You MUST release the "learn" button as soon as LED's 2&3 start to flash so you don't accidentally erase all slots). Now operate a Transmitter button that has been learnt into the receiver previously. The receiver will flash out the transmitters stored slot number three times in a row (refer to the chart for the LED indications) then return to normal mode again. If no stored transmitters are received within a 30 second period the receiver will automatically return to normal mode. Alternatively, you can momentarily press the "learn" button to terminate "Find" mode.

**Operation**

In Normal Mode, LED 1 turns on every time a signal is received. If the signal matches one of the stored slots, then the appropriate relay will also turn on. If Link A is fitted, the relay associated with the link will be energised for the duration of a valid transmission and then turn off 1 second after the transmission ends. Link 1 relates to relay # 1 and Link 2 relates to relay # 2.

If Link A is removed, the relay associated with the link will be energised when a valid transmission is received and remain in that state until another valid

Chart 1	RADIO SLOT NUMBER LED INDICATIONS			
RADIO TX # ↓	LED # 1	LED # 2	LED # 3	RADIO TRANSMITTER ISSUED TO; ↓
TX # 1	1 Flash	-	-	
TX # 2	2 Flashes	-	-	
TX # 3	3 Flashes	-	-	
TX # 4	4 Flashes	-	-	
TX # 5	5 Flashes	-	-	
TX # 6	1 Flash	On	-	
TX # 7	2 Flashes	On	-	
TX # 8	3 Flashes	On	-	
TX # 9	4 Flashes	On	-	
TX # 10	5 Flashes	On	-	
TX # 11	1 Flash	-	On	
TX # 12	2 Flashes	-	On	
TX # 13	3 Flashes	-	On	
TX # 14	4 Flashes	-	On	
TX # 15	5 Flashes	-	On	
TX # 16	1 Flash	On	On	
TX # 17	2 Flashes	On	On	
TX # 18	3 Flashes	On	On	
TX # 19	4 Flashes	On	On	
TX # 20	5 Flashes	On	On	